

KESİT U-U

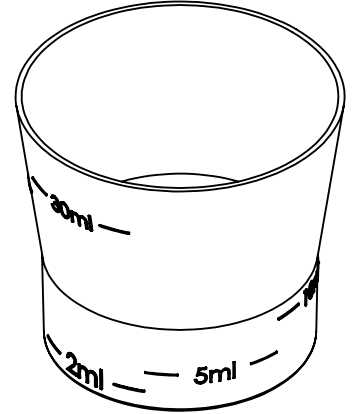
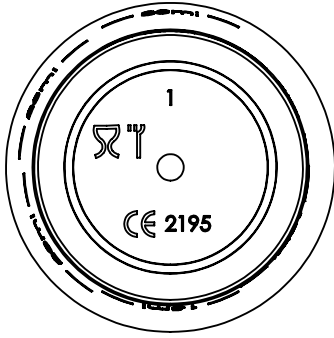
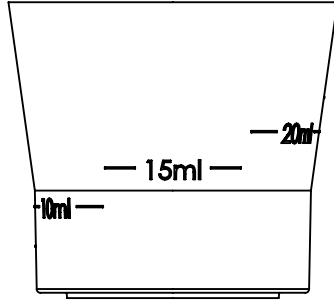

AKSİ BELİRTİLMEDİĞİ SÜRECE:
BOYUTLAR MİLMETREDİR
YÜZEY CİLASI:
TOLERANS: +/- 0.5mm
DOĞRUSAL:
AÇISAL:

BİTİRME:

09.11.2018

KESKİN KENARLARI
PAHLAYIN VE
KIRIN

TEKNİK RESMİ ÖLÇEKLENDİRME

REVİZYON

2-30 ml. 31x20 Şurup Kadehi

İSİM	İMZA	TARİH
ÇİZEN	AHMET ÖZKAYA	09.11.2018
ONAY.	SELİM OĞUZLU	09.11.2018
ÜRET.	CEMİL UÇAN	09.11.2018
KALİTE	ŞAFAK VARLI	09.11.2018

BAŞLIK:

ŞEN-PA PLASTİK EŞYA KALIP
İMALATI SAN. TİC. LTD. ŞTİ

MALZEME:

PP

RESİM NO.

047

A4

AĞIRLIK: 4 gr +/- 0,5

ÖLÇEK: 1/1

SAYFA : 1/1