

İKESİT M-M
ÖLÇEK 3 : 2

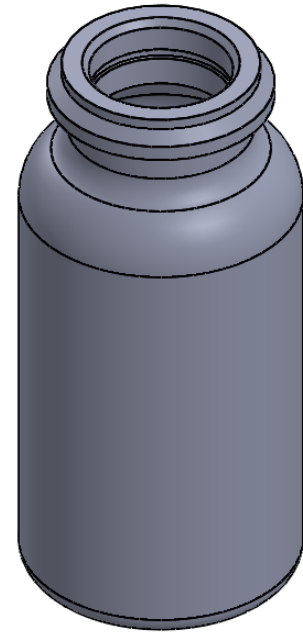
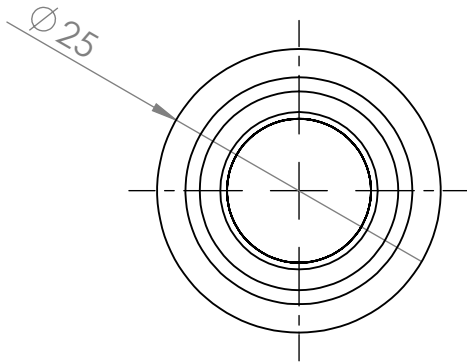

AKSİ BELİRTİLMEDİĞİ SÜRECE:
BOYUTLAR MİLMETREDİR
YÜZEY ÇILASI:
TOLERANS: +/- 0.5mm
DOĞRUSAL:
AÇISAL:

BİTİRME:

19.10.2017

KESKİN KENARLARI
PAHLAYIN VE
KIRIN

TEKNİK RESMİ ÖLÇEKLENDİRME

REVİZYON

15 ml. Flekon Şişe

	İSİM	İMZA	TARİH
ÇİZEN	AHMET ÖZKAYA		19.10.2017
ONAY.	SELİM OĞUZLU		19.10.2017
ÜRET.	CEMİL UÇAN		19.10.2017
KALİTE	ŞAFAK VARLI		19.10.2017

BAŞLIK:

ŞEN-PA PLASTİK EŞYA KALIP
İMALATI SAN. TİC. LTD. ŞTİ

MALZEME:

HDPE

RESİM NO.

516

A4

ŞİLME HACMİ: 18 ml. +/- 0.5

AĞIRLIK: 4.1 gr +/- 0.5

ÖLÇEK: 3/2

SAYFA: 1/1